



## Air Cooled Chiller Product Data Catalog

Modules ASP010X, ASP015X, ASP020X, ASP030X, ASP060X  
Includes Pump, Free Cooling and Accessory Modules





## Table of Contents

|   |       |
|---|-------|
| Model Number Nomenclature .....           | 3-4   |
| General Data Table .....                  | 5-6   |
| Pump Selection Charts .....               | 7     |
| Module Configuration .....                | 8     |
| Chiller Drawings .....                    | 9-10  |
| Required Piping and Electrical Data ..... | 11    |
| Mechanical Specifications .....           | 12-13 |

**Air Cooled Modular**

|     |     |   |     |   |   |   |   |   |   |   |   |   |   |   |  |
|-----|-----|---|-----|---|---|---|---|---|---|---|---|---|---|---|--|
| ASP | 030 | X | C/N | 1 | 1 | H | 1 | A | L | 1 | A | A | A | S | -410A  |
|     |     |   |     |   |   |   |   |   |   |   |   |   |   |   | Refrigerant <sup>8</sup>   |
|     |     |   |     |   |   |   |   |   |   |   |   |   |   |   | Fan Configuration <sup>7</sup>   |
|     |     |   |     |   |   |   |   |   |   |   |   |   |   |   | Condenser Coating <sup>6</sup>   |
|     |     |   |     |   |   |   |   |   |   |   |   |   |   |   | Condenser <sup>5</sup>   |
|     |     |   |     |   |   |   |   |   |   |   |   |   |   |   | Evaporator <sup>4</sup>  |
|     |     |   |     |   |   |   |   |   |   |   |   |   |   |   | AHRI Version   |
|     |     |   |     |   |   |   |   |   |   |   |   |   |   |   | Ambient ( L - Low, S - Standard, H - high, C - low & high)                       |
|     |     |   |     |   |   |   |   |   |   |   |   |   |   |   | Application <sup>3</sup>   |
|     |     |   |     |   |   |   |   |   |   |   |   |   |   |   | Power Connection (1 - Direct Connect, 2 - Multiple Module Connections)           |
|     |     |   |     |   |   |   |   |   |   |   |   |   |   |   | Voltage <sup>2</sup>   |
|     |     |   |     |   |   |   |   |   |   |   |   |   |   |   | Frame Designation 1 - 32 x 58, 2 - 36 x 72, 3 - 36 x 84, 4 - 72 x 84, 5 - other) |
|     |     |   |     |   |   |   |   |   |   |   |   |   |   |   | No. of Refrigerant Circuits ( 1 - single , 2 - dual, 4 - four)                   |
|     |     |   |     |   |   |   |   |   |   |   |   |   |   |   | AHRI Certified (C - certified, N - Not certified)                                |
|     |     |   |     |   |   |   |   |   |   |   |   |   |   |   | Compressor Type <sup>1</sup>   |
|     |     |   |     |   |   |   |   |   |   |   |   |   |   |   | Module Nominal Capacity (10-75 tons, needs 3 digits)                             |
|     |     |   |     |   |   |   |   |   |   |   |   |   |   |   | Series   |

<sup>1</sup> A - Copeland Scroll (ZR), B-Bristol, C - Trane Cornerstone, F-Danfoss Turbocor Flooded, R - Bitzer Screw, S - Trane Scroll, T - Danfoss Turbocor DX, Z - Copeland scroll (old elec), X - Copeland Scroll (ZP), N-None  
<sup>2</sup> A - 208/3/60, L - 230/3/60, H - 460/3/60, C - 575/3/60, D - 200/3/50, E - 400/3/50, F - 380/3/60, S - 220/230/1/60, V - Other  
<sup>3</sup> A - Air Cooled, C - Remote Condenser, D - Cond Unit, H-Heat Recovery, R - Heat Pump  
<sup>4</sup> A - Brazed SS, B - Brazed SMO, C- S&T copper, D - S&T cu-Ni, V - Other, N-None  
<sup>5</sup> A - Cu tube Al fin, B - Cu tube Cu fin, C- Microchannel, V - Other  
<sup>6</sup> A - None, B - Bronzeglow, H - Heresite, E - Electrofin, V - Other  
<sup>7</sup> S - Standard, H - High static, L -Low sound, V -Other  
<sup>8</sup> R-410A or R-134a

**Pump Module**

|     |   |     |   |   |   |   |   |   |
|-----|---|-----|---|---|---|---|---|---|
| PMP | 2 | 015 | A | H | S | M | Y |   |
|     |   |     |   |   |   |   |   | Misc Other Comp (Y - Yes other comp., N - No other comp.)                                     |
|     |   |     |   |   |   |   |   | Glycol Shot Feeder (M - Mini shot feeder & Exp tank, T - Exp tank, N - None)                  |
|     |   |     |   |   |   |   |   | Water Piping (C - Copper, S - Stainless, P - PVC, B - Black iron, V - Other)                  |
|     |   |     |   |   |   |   |   | Voltage <sup>1</sup>  |
|     |   |     |   |   |   |   |   | Configuration (A - 100% Redundant, D - Dual Arm configuration, S - Single pump)               |
|     |   |     |   |   |   |   |   | Pump Horsepower (HP of one pump)( Three digits)   |
|     |   |     |   |   |   |   |   | Frame Designation ( 1 - 32 x 58, 2 - 36 x 72, 3 - 36 x 84, 4 - 72 x 84, 5- other, 9 - Indoor) |
|     |   |     |   |   |   |   |   | Series (PMP, Pump Module)   |

<sup>1</sup> A - 208/3/60, L - 230/3/60, H - 460/3/60, C - 575/3/60, D - 200/3/50, E - 400/3/50, F - 380/3/60, S - 220/230/1/60, V - Other

**Model Number Nomenclature**

**Free Cool / Dry Cooler / Remote Condenser Module**

|     |   |   |   |   |   |   |   |
|-----|---|---|---|---|---|---|---|
| FCP | 2 | H | C | A | A | S |   |
|     |   |   |   |   |   |   | Fan Config (S - Standard, V - Other)  |
|     |   |   |   |   |   |   | Coil Coating (A - None, B - Bronzeglow, H - Heresite, E - Electrofin, V - Other)  |
|     |   |   |   |   |   |   | Coil (A - Cu tube Al fin, B - Cu tube Cu fin, C - Microchannel, V - Other)  |
|     |   |   |   |   |   |   | Water Piping (C - Copper, S - Stainless, P - PVC, B - Black iron, V - Other, N - None)  |
|     |   |   |   |   |   |   | Voltage <sup>1</sup>  |
|     |   |   |   |   |   |   | Frame Designation ( 1 - 32 x 58, 2 - 36 x 72, 3 - 36 x 84, 4 - 72 x 84, 5- other; A - 3V, B - 4V, C - 5V, D - 6V, E - 7V, F - 8V) |
|     |   |   |   |   |   |   | Series (FCP - FreeCool Module, DCP - Dry Cooler, RCP - Remote Condenser)  |

<sup>1</sup> A - 208/3/60, L - 230/3/60, H - 460/3/60, C - 575/3/60, D - 200/3/50, E - 400/3/50, F - 380/3/60, S - 220/230/1/60, V - Other

**Accessory Module**

|     |   |   |   |     |   |   |   |  |
|-----|---|---|---|-----|---|---|---|--|
| ACP | 2 | H | C | 180 | M | B | S | C  |
|     |   |   |   |     |   |   |   | Strainer materials of construction <sup>2</sup>  |
|     |   |   |   |     |   |   |   | Basket Strainer (S - Single, D - Duplex, L - Lakos, N- None)   |
|     |   |   |   |     |   |   |   | Air Separator (Y - Yes, N - None)  |
|     |   |   |   |     |   |   |   | Glycol Shot Feeder (L-Large shot feeder & Exp tank, M - Mini shot feeder & Exp tank, T - Exp tank, N - None) |
|     |   |   |   |     |   |   |   | Tank Volume (Three digits: 000=None)(Gallons)  |
|     |   |   |   |     |   |   |   | Water Piping (C - Copper, S - Stainless, P - PVC, B - Black iron, V - Other)                                 |
|     |   |   |   |     |   |   |   | Voltage <sup>1</sup>   |
|     |   |   |   |     |   |   |   | Frame Designation ( 1 - 32 x 58, 2 - 36 x 72, 3 - 36 x 84, 4 - 72 x 84, 5- other)                            |
|     |   |   |   |     |   |   |   | Series (ACP - Accessory Component Module)  |

<sup>1</sup> A - 208/3/60, L - 230/3/60, H - 460/3/60, C - 575/3/60, D - 200/3/50, E - 400/3/50, F - 380/3/60, S - 220/230/1/60, V - Other

<sup>2</sup> B - Bronze, C - Copper, S - Stainless, N-None, V - Other





| General Data Table of Air Cooled Standard –X Modules |                  |                  |                  |                  |                  |
|--|------------------|------------------|------------------|------------------|------------------|
| <b>Compressor</b>                                    | <b>ASP010X</b>   | <b>ASP015X</b>   | <b>ASP020X</b>   | <b>ASP030X</b>   | <b>ASP060X</b>   |
| Type   | SCROLL           | SCROLL           | SCROLL           | SCROLL           | SCROLL           |
| Nominal Capacity (per compressor)                    | 5                | 7.5              | 10               | 15               | 30               |
| Quantity   | 2-TANDEM         | 2-TANDEM         | 2-TANDEM         | 2-TANDEM         | 2-TANDEM         |
| <b>Evaporator</b>                                    | <b>ASP010X</b>   | <b>ASP015X</b>   | <b>ASP020X</b>   | <b>ASP030X</b>   | <b>ASP060X</b>   |
| Type   | BRAZED PLATE     | BRAZED PLATE     | BRAZED PLATE     | BRAZED PLATE     | BRAZED PLATE     |
| Weight   | 54.4             | 63.8             | 83.7             | 100              | 214.4            |
| Quantity   | 1                | 1                | 1                | 1                | 1                |
| Mechanical Module Front Fluid Volume (Gal.)          | 7.48             | 7.8              | 20.03            | 23.54            | 41.9             |
| Mechanical Module Rear Fluid Volume (Gal.)           | 1.08             | 1.4              | 2.03             | 2.54             | N/A              |
| Refrigerant Type                                     | 410A             | 410A             | 410A             | 410A             | 410A             |
| Number of Circuits                                   | 1                | 1                | 1                | 1                | 1                |
| Charge (lbs./circuit)                                | 21               | 25               | 30               | 45               | 100              |
| <b>Condenser Fans</b>                                | <b>ASP010X</b>   | <b>ASP015X</b>   | <b>ASP020X</b>   | <b>ASP030X</b>   | <b>ASP060X</b>   |
| Motor Type   | Totally Enclosed | Totally Enclosed | Totally Enclosed | Totally Enclosed | Totally Enclosed |
| HP   | 1                | 1                | 2                | 2                | 2                |
| Quantity   | 2                | 2                | 2                | 2                | 4                |
| Fan Type   | Axial            | Axial            | Axial            | Axial            | Axial            |
| Fan Material   | Composite        | Composite        | Composite        | Composite        | Composite        |
| Air Flow (cfm) (per module)                          | 8,400            | 12,000           | 18,000           | 23,000           | 47,200           |
| <b>Condenser Coils*</b>                              | <b>ASP010X</b>   | <b>ASP015X</b>   | <b>ASP020X</b>   | <b>ASP030X</b>   | <b>ASP060X</b>   |
| Fin Material   | Aluminum         | Aluminum         | Aluminum         | Aluminum         | Aluminum         |
| Tube Material  | Copper           | Copper           | Copper           | Copper           | Copper           |
| Tube Diameter (mm)                                   | 7 mm             | 7 mm             | 7 mm             | 7 mm             | 7 mm             |
| Number of Rows                                       | 4                | 4                | 4                | 4                | 4                |
| Coil Dimensions (Quantity)                           | 30 x 50.5 (2)    | 30 x 50.5 (2)    | 30 x 65 (2)      | 42 x 77 (4)      | 42 x 77 (4)      |
| <b>Operating Weight (with AL/CU coils)</b>           | 1,430            | 1,470            | 1,820            | 2,290            | 4,350            |
| <b>Shipping Weight (with AL/CU coils)</b>            | 1,370            | 1,400            | 1,700            | 2,100            | 4,000            |
| <b>Operating Weight (with CU/CU coils)</b>           | 1,650            | 1,770            | 2,300            | 2,920            | 5,610            |
| <b>Shipping Weight (with CU/CU coils)</b>            | 1,590            | 1,700            | 2,180            | 2,730            | 5,260            |

\*On Free Cooling Modules, coils are used as water precoolers rather than for refrigerant condensing.

| General Data Table, Standard Air-Cooled Free Cooling Modules |                  |                  |                  |                  |
|--|------------------|------------------|------------------|------------------|
|  | FCP1             | FCP2             | FCP3             | FCP4             |
| <b>Fans</b>  |                  |                  |                  |                  |
| Motor Type   | Totally Enclosed | Totally Enclosed | Totally Enclosed | Totally Enclosed |
| HP   | 1                | 2                | 2                | 2                |
| Quantity   | 2                | 2                | 2                | 2                |
| Fan Type   | Axial            | Axial            | Axial            | Axial            |
| Fan Material   | Comp             | Comp             | Comp             | Comp             |
| Air Flow (cfm) (per module)                                  | 8,500            | 16,000           | 22,000           | 44,000           |
|  | FCP01            | FCP02            | FCP03            | FCP04            |
| <b>Coils*</b>  |                  |                  |                  |                  |
| Fin Material   | Aluminum         | Aluminum         | Aluminum         | Aluminum         |
| Tube Material  | Copper           | Copper           | Copper           | Copper           |
| Tube Diameter (in.)  | 1/2              | 1/2              | 1/2              | 1/2              |
| Number of Rows   | 6                | 6                | 6                | 6                |
| Coil Dimensions (Quantity)                                   | 30 x 49 (2)      | 30 x 61½ (2)     | 42 x 73½ (2)     | 42 x 73½ (4)     |
| Free Cooling Front Fluid Volume (Gal.)                       | 23.6             | 44.5             | 59.5             | 110.6            |
| Free Cooling Rear Fluid Volume (Gal.)                        | 14               | 17.5             | 28               | 56               |
| Module Dry Weight (lb.)                                      | 1150             | 1550             | 1850             | 3400             |

*\*On Free Cool Modules, coils are used as water precoolers rather than for refrigerant condensing.*



**ASP DUAL PUMP SELECTION CHART***(ALL PUMPS IN PRIMARY/STANDBY ARRANGEMENT—DATA FOR SINGLE PUMP)***Charts Show Pump BHP Requirement at Given Condition**

| <b>3x3x6 Pump</b>         |           |           |            |            |            |
|---------------------------|-----------|-----------|------------|------------|------------|
| <b>Total head in feet</b> |           |           |            |            |            |
| <b>Flow (USGPM)</b>       | <b>60</b> | <b>80</b> | <b>100</b> | <b>120</b> | <b>140</b> |
| <b>40</b>                 |           | 3.07      | 3.87       | 4.66       | 5.47       |
| <b>80</b>                 |           | 3.58      | 4.47       | 5.37       | 6.29       |
| <b>120</b>                | 3.55      | 4.52      | 5.51       | 6.50       | 7.51       |
| <b>160</b>                | 4.82      | 5.91      | 7.00       | 8.09       | 9.20       |
| <b>200</b>                | 6.71      | 7.94      | 9.13       | 10.34      |            |
| <b>240</b>                |           | 10.97     | 12.27      |            |            |

| <b>4x4x6 Pump</b>         |           |           |            |            |            |
|---------------------------|-----------|-----------|------------|------------|------------|
| <b>Total head in feet</b> |           |           |            |            |            |
| <b>Flow (USGPM)</b>       | <b>60</b> | <b>80</b> | <b>100</b> | <b>120</b> | <b>140</b> |
| <b>50</b>                 |           | 3.80      | 4.89       | 6.10       | 7.44       |
| <b>100</b>                |           | 4.52      | 5.77       | 7.12       | 8.57       |
| <b>150</b>                | 3.98      | 5.30      | 6.70       | 8.16       | 9.71       |
| <b>200</b>                | 4.78      | 6.26      | 7.79       | 9.39       |            |
| <b>250</b>                | 5.81      | 7.54      | 9.14       | 10.90      |            |
| <b>300</b>                | 7.16      | 9.03      | 10.91      |            |            |
| <b>350</b>                | 8.90      | 11.07     |            |            |            |

| <b>6x6x6 Pump</b>         |           |           |            |            |            |
|---------------------------|-----------|-----------|------------|------------|------------|
| <b>Total head in feet</b> |           |           |            |            |            |
| <b>Flow (USGPM)</b>       | <b>60</b> | <b>80</b> | <b>100</b> | <b>120</b> | <b>140</b> |
| <b>200</b>                |           | 7.86      | 10.24      | 12.78      | 15.47      |
| <b>300</b>                |           | 9.75      | 12.39      | 15.15      |            |
| <b>400</b>                | 8.99      | 11.82     | 14.73      | 17.72      |            |
| <b>500*</b>               | 10.93*    | 14.14*    | 17.34*     | 20.59*     |            |
| <b>600*</b>               | 13.06*    | 16.68*    | 20.26*     |            |            |
| <b>700*</b>               | 15.48*    | 19.51*    |            |            |            |
| <b>800*</b>               | 18.35*    | 22.76*    |            |            |            |

\*For selections above 400 gpm contact Multistack®

**Notes:**

1. DO NOT SELECT IN SHADED AREA.
2. All selections are based on 40% Ethylene Glycol solution.
3. Pump speed is 3,600 rpm.
4. All pump modules have automatic changeover controls in the event of loss of flow and manual lead/lag selector switch.

**Module Configurations**

**IMPORTANT MODULE CONFIGURATION INFORMATION**

**PMP1, PMP2, PMP3, PMP4, PMP9 PUMP MODULE:**

1. When present, a Pump Module is only allowed in the "Front" position.
2. Incoming water to the chiller system must enter at the Pump Module.
3. Leaving water from the chiller system may be from either end of the chiller.

**FCP1, FCP2, FCP3 FREE COOL MODULE:**

1. When present, incoming system water must enter through the Free Cool Modules prior to entering an ASP010X, 15X, 20X, 30X, 60X Chiller Module.
2. You may not attach a Rear Free Cool Module to a Front ASP010X, 15X, 20X, 30X, 60X Chiller Module.

**ACP GLYCOL FEEDER MODULE:**

1. An ACP Glycol Feeder Module may be attached in any rear position.

**ASP010X, 15X, 20X, 30X, 60X CHILLER MODULE:**

1. The maximum number of ASP010X, 015X, 020X, or 030X modules with a single Master Module is 14 (i.e., (1) Front-Master, (6) Front-Slaves, and (7) Rear-Slaves). For 60X modules, the maximum is nine modules.
2. You may have more than one Master Module in a single chiller bank.
3. Piping sides of an ASP010X, 015X, 020X, 030X, 060X chiller without Free Cool or Pump Modules attached are field selectable.

**LEGEND: FIRST LETTER**

- M=Master Chiller Module (ASP010X, 15X, 20X, 30X or 60X)
- S = Slave Chiller Module (ASP010X, 15X, 20X, 30X or 60X)
- P= Pump Module (ASP-00P)
- F = Free Cool Module (ASP-1FX, 2FX, 3FX)
- G = Glycol Feeder Module (ASP-00G)

**SECOND LETTER**

- F = Front Module
- R = Rear Module

**FRONT OF CHILLER BANK IS TOWARD THE BOTTOM OF THE PAGE**

*(Master Module location determines front of chiller)*

For other configurations, contact your local Multistack® Representative.

**VALID CONFIGURATIONS**

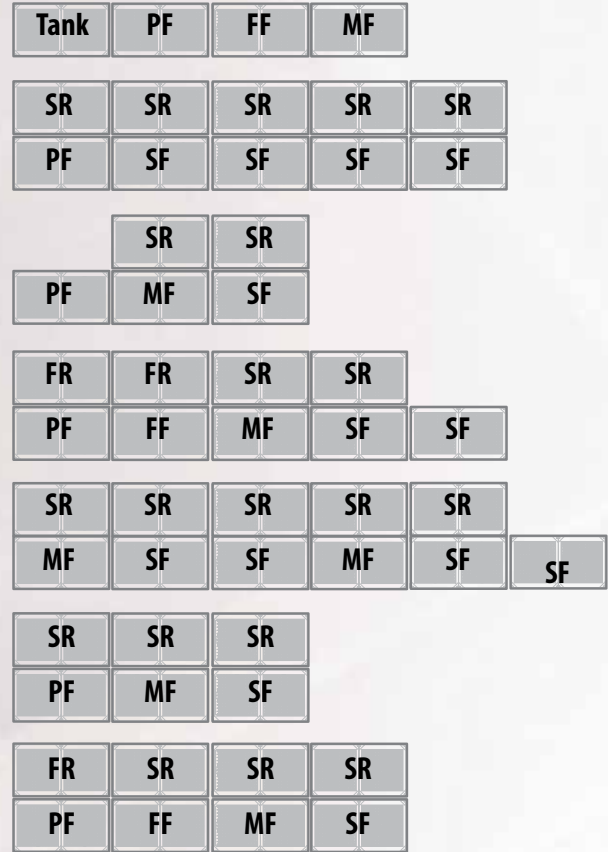

**INVALID CONFIGURATIONS**



Problem: Cannot have a stand alone rear module.  
Solution: Make Slave Rear a Slave Front.



Problem: Pump module after Master.  
Solution: Swap placement so incoming water enters at the pump module.



Problem: Glycol Feeder Module is attached in a front position.  
Solution: Move Glycol Feeder Module to rear position and exchange Slave Rear Module for Slave Front Module.

**TYPICAL ASP060X CONFIGURATION**





Multiple Modules

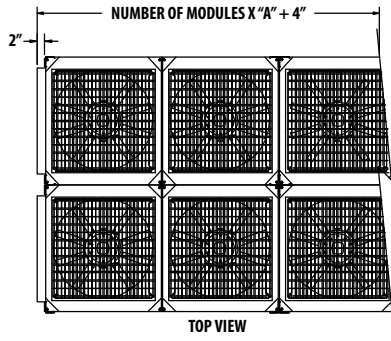

|   | ASP-010X, -015X | ASP-020X | ASP-030X |
|---|-----------------|----------|----------|
| A | 57 7/8"         | 72"      | 84"      |
| B | —               | —        | —        |
| C | 74 7/8"         | 76 5/16" | 89 5/16" |
| D | 31 1/2"         | 36"      | 36"      |

NOTES:

1. NO OBSTRUCTIONS ALLOWED ABOVE CONDENSER FANS.
2. REQUIRED SERVICE CLEARANCE AT MODULE ENDS: 36"
3. REQUIRED AIR INTAKE CLEARANCE: 42" (Unobstructed)\*
4. REQUIRED CLEARANCE FROM ANY HIGH VOLTAGE PANEL: 42"

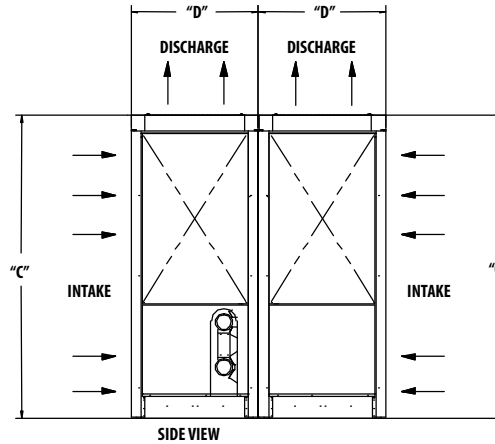
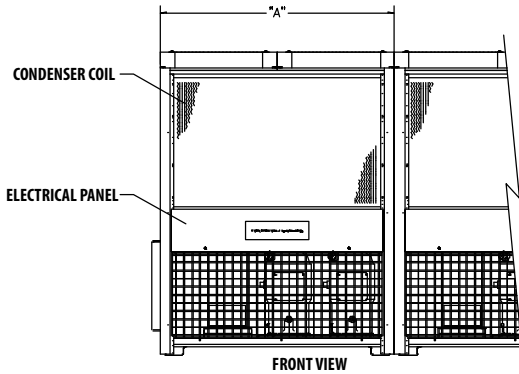

Single Modules

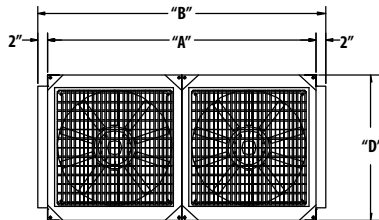

|   | ASP-010X, -015X | ASP-020X | ASP-030X |
|---|-----------------|----------|----------|
| A | 57 7/8"         | 72"      | 84"      |
| B | 61 7/8"         | 76"      | 88"      |
| C | 74 7/8"         | 76 1/2"  | 88 5/16" |
| D | 31 1/2"         | 36"      | 36"      |

NOTES:

1. NO OBSTRUCTIONS ALLOWED ABOVE CONDENSER FANS.
2. REQUIRED SERVICE CLEARANCE AT MODULE ENDS: 36"
3. REQUIRED AIR INTAKE CLEARANCE: 42"\*
4. REQUIRED CLEARANCE FROM ANY HIGH VOLTAGE PANEL: 42"
5. REQUIRED CLEARANCE FROM ANY GROUNDED WALL: 36"
6. NO CLEARANCE REQUIRED FROM REAR.

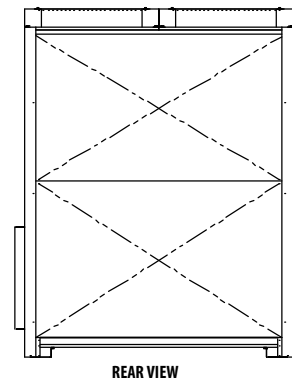
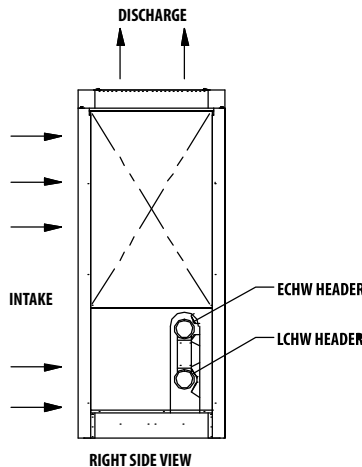
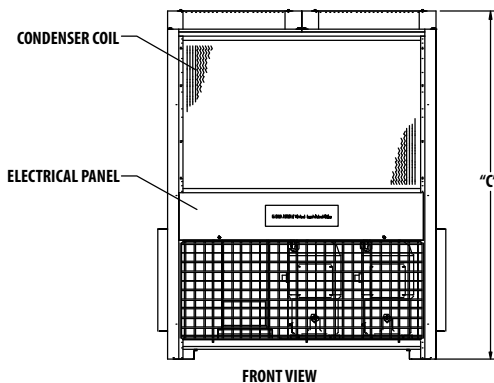

Note: If installation is in a pit or near walls that are taller than modules, contact Multistack for clearances.

Chiller Dimensions

All ASP060X units come standard with four multi-blade vane axial condenser fans.

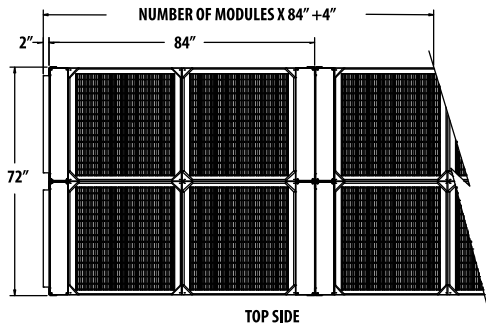

TOP SIDE

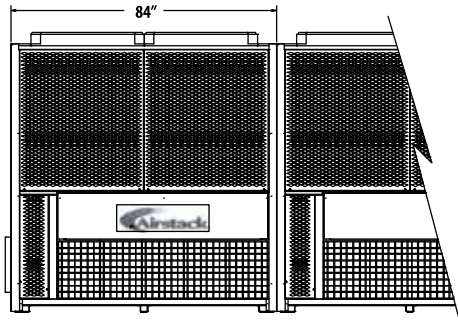

FRONT SIDE

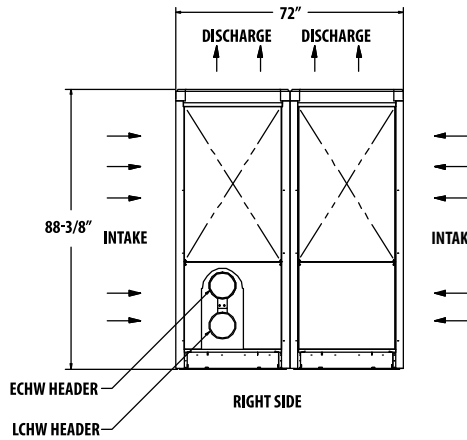

**ASP-60X  
MULTIPLE MODULE**

**NOTES:**

- NO OBSTRUCTIONS ALLOWED ABOVE CONDENSER FANS.
- REQUIRED SERVICE CLEARANCE AT MODULE ENDS: 42"
- REQUIRED AIR INTAKE (FRONT) CLEARANCE: 42"
- REQUIRED CLEARANCE FROM ANY HIGH VOLTAGE PANEL: 42"

**Note:** If installation is in a pit or near walls that are taller than modules, contact Multistack for clearances.

**ASP060X Notes:**

1. No obstructions allowed above condenser fans.
2. Required service clearance at module ends: 42"
3. Required air intake (front) clearance: 42"
4. Required clearance from any high voltage panel 42"
5. Required clearance from any grounded wall: 42"  
Any non-grounded wall: 36"

**REQUIRED CHILLED-WATER PIPING  
(SUPPLIED AND INSTALLED BY OTHERS)**

(\*If Pump Module is Supplied by Airstack, eliminate external pump shown below.)

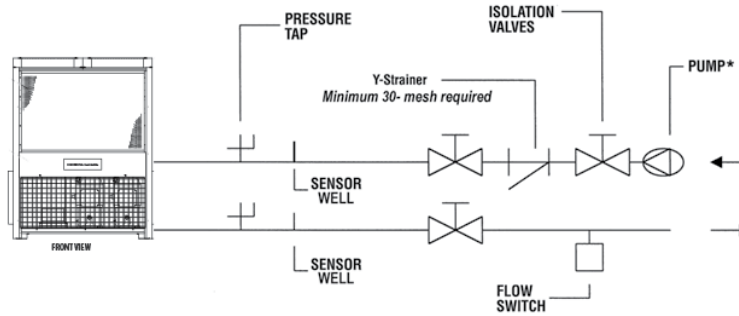

**CHILLER MODULE ELECTRICAL DATA**

| Model   | Number of Compressors | RLA per Compressor |         | Number of Fan Motors | FLA per Fan Motor |         |
|---------|-----------------------|--------------------|---------|----------------------|-------------------|---------|
|         |                       | 3 phase            | 1 phase |                      | 3 phase           | 1 phase |
|         |                       | 208/460/575V       | 230V    |                      | 208/460/575V      | 230V    |
| ASP010X | 2                     | 19.5/8.7/7.2       | 25.0    | 2                    | 4.0/2.0/1.5       | 5.0     |
| ASP015X | 2                     | 31/14.0/11.5       | N/A     | 2                    | 4.0/2.0/1.5       | N/A     |
| ASP020X | 2                     | 35/15.5/12.0       | N/A     | 2                    | 7.4/3.6/2.9       | N/A     |
| ASP030X | 2                     | 55/26.0/21.0       | N/A     | 2                    | 7.4/3.6/2.9       | N/A     |
| ASP060X | 2                     | N/A/47.0/38.0      | N/A     | 4                    | 7.4/3.6/2.9       | N/A     |

**FREE COOLING MODULE FAN ELECTRICAL DATA**

| Model | Number of Fan Motors | FLA per Fan Motor |         |
|-------|----------------------|-------------------|---------|
|       |                      | 3 phase           | 1 phase |
|       |                      | 208/460/575V      | 230V    |
| FCP 1 | 2                    | 4.0/2.0/1.5       | N/A     |
| FCP 2 | 2                    | 7.4/3.6/2.8       | N/A     |
| FCP 3 | 2                    | 7.4/3.6/2.8       | N/A     |
| FCP 4 | 4                    | 7.4/3.6/2.9       | N/A     |

*NOTE: Various HP pumps can be used with various pump and accessory modules.*

**PUMP AND ACCESSORY MODULE ELECTRICAL DATA**

| Pump HP | Max Pump FLA*  |         |
|---------|----------------|---------|
|         | 3 phase        | 1 phase |
|         | 208/460/575V   | 230V    |
| 5       | 15.0/6.8/5.5   | N/A     |
| 7.5     | 21.8/9.9/8.1   | N/A     |
| 10      | 27.7/12.6/9.9  | N/A     |
| 15      | 41.6/18.9/15.3 | N/A     |
| 20      | 53.5/24.3/19.8 | N/A     |
| 25      | 67.3/30.6/24.3 | N/A     |

*\*Pump motor nameplates are unique to each job. Amperage may vary slightly.*

**WIRING SIZING (MCA= MINIMUM CIRCUIT AMPACITY)**

$MCA = (1.25 \times RLA1^*) + RLA2 + RLA3 \dots$

**FUSE SIZING (MFS = MAXIMUM FUSE SIZE)**

$MFS = (2.25 \times RLA1^*) + RLA2 + RLA3 \dots$

Where MFS does not equal a standard size fuse, the next larger fuse should be used.

**NOTES:**

1. Compressor Rated Load Amps (RLA) are based on 125°F Saturated Condensing Temperature.
2. \*RLA1 = RLA of the largest motor in the system. RLA2 & RLA3 = RLA of other motors in the system.
3. Wire sizing is based on Nat. Electr. Code (NEC) rating for 75°C wire, with 3 wires per conduit.
4. Wiring distance from branch circuit shall not exceed 100 feet.

| MCA | WIRE SIZE (AWG) 75°<br>(3 Conductors/1Conduit) |
|-----|--|
| 50  | 8  |
| 65  | 6  |
| 85  | 4  |
| 100 | 3  |
| 115 | 2  |
| 130 | 1  |
| 150 | 1/0  |
| 175 | 2/0  |
| 200 | 3/0  |
| 230 | 4/0  |
| 255 | 250 MCM  |
| 285 | 300 MCM  |
| 310 | 350 MCM  |
| 335 | 400 MCM  |
| 380 | 500 MCM  |
| 420 | 600 MCM  |

| MCA | WIRE SIZE (AWG) 75°<br>(6 Conductors/2Conduit) |
|-----|--|
| 510 | 250 MCM  |
| 570 | 300 MCM  |
| 620 | 350 MCM  |
| 670 | 400 MCM  |
| 760 | 500 MCM  |
| 800 | 600 MCM  |

## Mechanical Specifications

### GENERAL

Chiller Modules shall be ETL listed in accordance with UL Standard 1995, CSA certified per Standard C22.2#236.

Modules shall ship wired and charged with refrigerant. All modules shall be factory run-tested prior to shipment. Compressors, heat exchangers, condenser fans, piping, and controls shall be mounted on a heavy-gauge steel frame. Electrical controls, contactors, and relays for each module shall be mounted within that module. The module shall be provided within a steel enclosure suitable for outdoor use. Exposed steel surfaces shall be provided with a powder-coat paint finish.

### CHILLED-WATER MAINS

Each module shall include supply and return mains for chilled water. Grooved end connections are provided for interconnection to four-inch (ASP 010X, 015X), six-inch (ASP 020X and 030X) or eight-inch (060X) standard piping with grooved-type couplings. Each inlet water header shall incorporate a built-in, 30-mesh in-line strainer system to prevent heat exchanger fouling.

### EVAPORATORS

Each evaporator shall be a brazed-plate heat exchanger constructed of 316 stainless steel, and be designed, tested, and stamped in accordance with U.L. 1995 650 PSIG working pressure.

### COMPRESSOR

Each module shall contain hermetic scroll compressor(s) mounted to the module with rubber-in-shear isolators. Each system shall also include high discharge-pressure and low suction-pressure safety cut-outs.

### CONDENSER COILS

Air cooled condenser coils shall have aluminum fins mechanically bonded to copper tubing. Condensers shall be factory leak-tested.

### CONDENSER FANS

Each module shall contain dual condenser fans. These fans shall be multi-blade vane-axial type, made of plastic composite material for quiet operation. Fans shall be direct driven at a maximum rpm of 1,150. All fan motors shall be pressure controlled and suitable for outdoor use. ASP 60X modules have four fans.

### CENTRAL CONTROL SYSTEM

Scheduling of the various compressors shall be performed by a microprocessor-based control system (Master Controller). A new lead compressor is selected every 24 hours to ensure even distribution of compressor run time. The Master Controller shall monitor and report the following on each refrigeration system:

- Discharge Pressure Fault
  - Suction Pressure Fault
  - Compressor Winding Temperature Fault
  - Suction Temperature
  - Evaporator Leaving Chilled-Water Temperature

The Master Controller shall monitor and report the following system parameters:

- Chilled-Water Entering and Leaving Temperature
  - Discharge Refrigerant Temperature
  - Chilled-Water Flow Fault

An out-of-tolerance indication from these controls or sensors shall cause a "fault" indication at the Master Controller and shutdown of that compressor, with the transfer of load requirements to the next available compressor. In the case of a System Fault, the entire chiller will be shut down. When a fault occurs, the Master Controller shall record conditions at the time of the fault and store the data for recall. This information shall be capable of being recalled through the keypad of the Master Controller and displayed on the Master Controller's LCD. A history of faults shall be maintained, including date and time-of-day of each fault (up to the last 20 occurrences).

Individual monitoring of leaving chilled-water temperatures from each refrigeration system shall be programmed to protect against freeze-up.

The control system shall monitor entering and leaving chilled water temperatures to determine system load, and select the number of compressor circuits required to operate. Response times and set points shall be adjustable.

### LOW AMBIENT OPERATION

Each refrigerant circuit shall include all refrigerant specialties to provide reliable operation down to 20°F ambient with proper freeze protection.

### OPTIONAL LOW AMBIENT TO -20°F

The chiller shall incorporate appropriate refrigerant specialties, including a properly sized refrigerant receiver and flooded head pressure control valves for

operation to -20°F.

#### **OPTIONAL SINGLE-POINT POWER CONNECTION**

The chiller shall be provided with a single-point power connection. This will include pre-engineered wiring for field installation and connection to a factory-mounted chiller junction box. The junction box shall include individual fusing for each Module Set and provide a single point of connection to building power.

#### **OPTIONAL FREE COOLING MODULE**

Free Cooling Modules shall interconnect through the common chiller header system and require no additional water connections. Free Cooling Modules shall include glycol cooling coils, temperature-controlled fans, and an automatic 3-way bypass valve to eliminate the need for mechanical cooling under low-ambient conditions. The module shall be completely factory-assembled and tested before shipment.

#### **OPTIONAL PUMP MODULE**

The Pump Module shall be interconnected through the common chiller header system and require no additional water connections. The Pump Module will become an integral part of the chiller system. The Pump Module shall incorporate dual in-line centrifugal pumps in a Primary/Standby pumping arrangement. Pump starters and controls shall be provided to enable manual selection of lead pump. In addition, in the event of a loss-of-flow failure of the chilled-water system, the Pump Module controls shall disable the lead pump and automatically start the standby pump. The Pump Module shall be completely factory assembled and tested prior to shipment.

#### **OPTIONAL TANK MODULE**

A factory-assembled Tank Module shall be provided, including an insulated chilled water tank. The tank shall be pressure-rated at 150 psi minimum. Tank Modules shall interconnect through the common chiller header system and require no additional water connections. The Tank Module will become an integral part of the chiller system. The Tank Module shall be provided with proper drain and fill valving.

#### **OPTIONAL GLYCOL FEEDER MODULE**

The optional Glycol Feeder and Expansion Tank shall be incorporated into the chiller system through a modular arrangement and interconnect through the common chiller header system, requiring no additional water connections. The system shall include a 48-gallon storage/mixing tank with lid and cover, pump suction hose with inlet strainer, pressure pump with thermal cut-out and integral pressure switch, pre-charged accumulator tank with EPDM diaphragm, manual diverter valve for purging and agitating contents of storage tank, adjustable 5-55 psi pressure regulating valve with pressure gauge, fast fill lever, integral replaceable strainer, built-in check valve, and built-in shutoff valve. The glycol feeder system shall be compatible with glycol solutions of up to 50% concentration. The pump shall be capable of running dry without damage. The expansion tank shall be welded steel with a butylrubber diaphragm, and capable of a maximum operating temperature of 240°F and a maximum working pressure of 100 psig. The tank shall be interconnected through the common chiller header system and require no additional water connections. The module shall be completely factory assembled and -tested prior to shipment.

#### **OPTIONAL SOUND-ATTENUATION MODULE**

1. Each Free Cooling module shall have VFD-controlled condenser fan motors soft start and precise fan speed control.
2. Each mechanical cooling module shall have oversized condenser coils and VFD controlled condenser fan motors that modulate to maintain head pressure for precise fan speed control. Fans shall have acoustically optimized fan blades utilizing a composite material. Compressors shall be wrapped with high-temperature acoustic covers consisting of a dense-design fabric exterior with quilted acoustical fiberglass interior and open edges sealed with silicone coated fabric with hook and loop closures.



# Originators. Innovators. Never the Imitators.<sup>SM</sup>

## Originators...

Multistack invented the modular water chiller. It started with a radically simple idea: chiller modules that could be brought into the equipment room one at a time, through standard doorways and down elevators, to form a fully integrated chiller system. The idea launched a revolution and transformed Multistack into a leader in the commercial water-chiller industry.

## Innovators...

Multistack perfected the modular chiller and leads the industry in innovative and environmentally friendly modular solutions. Since founding in the late 1980s, Multistack has engineered, manufactured, and distributed an impressive array of modular air conditioning firsts: the first on-board strainer, the first modular automatic blow-down device, the first modular chiller for variable flow, the first modular chiller-heater (heat pump), the first modular heat-recovery chiller, the first modular air-to-water heat pump, the first modular chiller to utilize MagLev™ compressor technology, and the first modular chiller to utilize R-410A.

## Never the Imitators...

Multistack sets the standard in the industry for superior customer service, fast and on time shipment, superior product quality, and new product development. Our pioneering leadership in environmental issues is well documented. If you want the best, be sure to specify the original – Multistack®.



 **MULTISTACK**<sup>®</sup>

1065 Maple Avenue P.O. Box 510 Sparta, WI 54656

Phone 608-366-2400 • Fax 608-366-2450

[www.multistack.com](http://www.multistack.com)



ASP-CAT-001\_0916

Supersedes ASP-CAT-001\_0416