



Dedicated Heat Recovery

By **Thomas H. Durkin, P.E.**, Member ASHRAE, and **James B. (Burt) Rishel, P.E.**, Fellow/Life Member ASHRAE

The advent of the small scroll or screw chiller, capable of producing condenser water as high as 140°F (60°C), created an opportunity for recovering heat from a dedicated heat recovery chiller's condenser water circuit for heating or domestic water systems while providing beneficial cooling for the chilled water system. These systems are called "dedicated" heat recovery because 100% of the heat generated by the dedicated heat recovery chiller (DHRC) can be used for hot water heating applications. Also, the DHRC can be piped and controlled to produce the desired evaporator or condenser temperature. Transfer of the recovered heat in this article is limited to clean water applications, such as preheating, heating, reheating, domestic, pool water heating, or snow melting.

The following article was published in ASHRAE Journal, October 2003. © Copyright 2003 American Society of Heating, Refrigerating and Air-Conditioning Engineers, Inc. It is presented for educational purposes only. This article may not be copied and/or distributed electronically or in paper form without permission of ASHRAE.

The ability to recover heat from a chiller's condenser has been improved due to the development of small tonnage compressors that can operate at high discharge pressures and be controlled from either the condenser or evaporator water temperatures. Some installations prove that more condenser heat is needed than originally planned. Modular units that can be expanded are a solution to such applications.

The heat recovery chiller introduces an efficient answer to simultaneous heating and cooling loads. Three ways to accomplish this are:

1. Run boilers and chillers,
2. Run boilers and operate air-side economizers, and
3. Run a heat recovery chiller.

Using a particular project's energy rates, operating boilers and chillers cost \$0.87 per 100 MBH (29.31 kW); boiler and economizers cost \$0.59 per 100 MBH (29.31 kW), while the heat recovery chiller required only \$0.38 per 100 MBH (29.31 kW). This demonstrated that operating the DHRC required only 43.7% of that for running boilers and the chiller, and 64.4% for running boilers and air-side economizer simultaneously for that installation. (Note: To develop the greatest efficiency, air-side economizer operation must be coordinated with the operation of the DHRC. This is very simple. Whenever the chilled water temperature is at 55°F (12.7°C) or lower, the air-side economizers are "locked out" and minimum outside air is provided. Whenever the chilled water supply temperature is above 55°F (12.7°C), the air-side economizers are allowed to operate normally.)

Uses of Recovered Heat

Recovered heat can be used in domestic water systems, air-handling unit preheat or heating coils, or VAV reheat coils. The ability to adjust condenser water temperatures to fit any of these heat recovery applications requires a chiller separate from the main chillers in the chiller plant for greatest potential efficiency.

The combination a DHRC, operating at elevated condenser water temperatures, and main, high-efficiency chillers, operating at the most efficient condenser water temperature allowed by ambient conditions, allows beneficial loading of the DHRC to serve heating loads, while the remainder of the cooling load is served by the more efficient main chillers. This combination results in a substantial improvement in the coefficient of performance (COP) for the entire chiller installation, compared to operating the main chillers at an elevated condenser water temperature with only a portion being used for beneficial heating.

When Can Heat Recovery be Used?

Recovered heat can be used when hot water and chilled water are employed simultaneously (i.e., chilled water used in the winter and hot water used in the summer). The same is true for facilities with sufficient internal loads that are served by water-side economizers. Also, installations that use a sizeable amount of domestic water throughout the year may be candi-

dates for condenser water heat reclamation. Hospitals dormitories, computer centers, and hotels are opportunities for economical heat recovery due to their needs for hot water for reheat and domestic use, coupled with air-side economizer operation, or in some cases, winter operation of chillers.. This is a requirement of ANSI/ASHRAE/IESNA Standard 90.1-2001, *Energy Standard for Buildings Except Low-Rise Residential Buildings*, for large facilities that operate continuously with large water heating and cooling loads.

Other applications include:

1. **Existing air-cooled chillers.** The installation of the DHRC provides a marked improvement in the overall chiller energy consumption whenever a corresponding requirement exists for hot water in the building (especially during winter operation). Further, when properly sized, the DHRC can eliminate the need to run the larger air-cooled chiller during the winter months, thus eliminating the associated operational problems of running air-cooled systems under low loads and low and low ambient temperature conditions (a typical application would be pool dehumidification systems).

2. **Installations using condensing type boilers for heating with relatively low hot water temperatures such as 130°F (54°C) supply water and 100°F (37.8°C) return water.** These applications increase the transfer of the heat from the condenser to the hot water. Non-condensing boilers must run with at least 140°F (60°C) water temperature and at 80% to 85% efficiency compared to condensing boiler efficiencies above 90%.

3. **Installations with water-side economizing.** Much of the same equipment can be used for condenser heat recovery.

Dedicated Heat Recovery Sizing

As indicated earlier, the economical application of the DHRC is dependent on a simultaneous need for hot water (at 130°F [54°C] or less) and chilled water. Therefore, size the system to provide for the maximum hours of simultaneous operation to achieve fastest payback.

Most customers who have applied these systems have expressed the desire to shut down their primary chilled water system during winter operation. If this is the case, size the DHRC for the maximum winter chilled water load. In theory, for applications in northern climates, the wintertime heating load will far exceed the winter cooling load. If this is the case, the DHRC will operate throughout the winter season to provide the facility's chilled water requirements and simultaneously provide hot water to supplement and unload the facility's main boiler system.

Similarly, some customers want to shut down their hot water systems in the summertime. This is especially the case when a large hot water boiler system is operated to provide a relatively small summer reheat requirement that could otherwise be satis-

About the Authors

Thomas H. Durkin, P.E., is director of engineering for Veazey, Parrott, Durkin, and Shoulders, Indianapolis. **James B. (Burt) Rishel, P.E.**, is a consultant with Pumping Solutions in Cincinnati.

fied by the relatively low hot water temperature (130°F to 140°F [54°C to 60°C]) of the DHRC. In this situation, the DHRC's heating capacity should be matched to the facility's maximum summer reheat load. For such applications, the DHRC will operate throughout the summer to provide the facility's heating and domestic water requirements and simultaneously provide chilled water to supplement, and unload, the main chiller system.

For installations that eliminate boiler operation in the summer and chiller operation in the winter, the payback for the installation of a DHRC system can be less than one year, depending on the local cost of electricity and natural gas. When sizing this system, compare the maximum winter chilled water load and the maximum summer hot water load. Select the DHRC to serve the larger of these two loads.

Instrumentation and Heat Balance

The basic instrumentation for the heat recovery chiller is shown in *Figure 1*. This includes the temperatures in and out of the evaporator and condenser, flows in both of them, and the kW input to the chiller.

The heat balance or COP for the heat recovery chiller can be computed by determining the cooling effect plus the heat recovered divided by the kW input in Btu/h. This assumes no heat is rejected to a cooling tower or closed circuit cooler.

The COP for the chiller is:

$$\text{COP} = \frac{\text{Cooling Effect} + \text{Heat Recovered}}{\text{kW input} \times 3,412} = \frac{500[F_1 \times (T_2 - T_1) + F_2 \times (T_4 - T_3)]}{\text{kW input} \times 3,412} \quad (1)$$

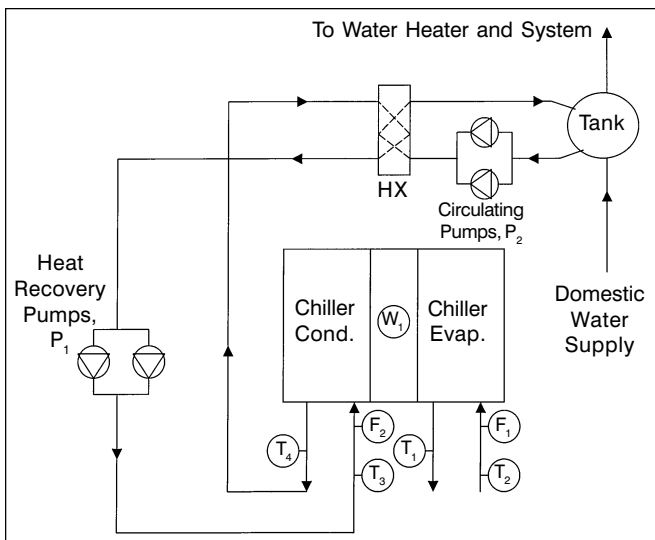

Figure 2: Domestic water heating.

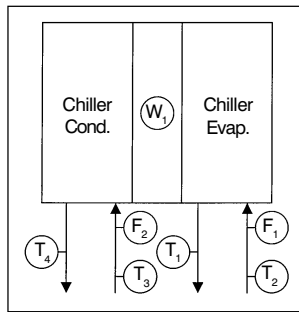

Figure 1: Basic chiller instrumentation.

the condenser

W_1 is the kilowatt input to the chiller

This equation does not include energy saved by not delivering the heat to the cooling tower or closed cooler fan. In addition to fan energy savings, the heat recovery chiller may reduce other operating costs for cooling towers, such as water treatment and makeup water.

The COP for a heat recovery chiller varies with the temperature of the water leaving the condenser. For example, when applying the heat to a hot water heating system or for reheat coils, the leaving temperature may be as high as 130°F. In this case, *Equation 1* provides the chiller COP with the following conditions.

$F_1 = 100$ gpm (6 L/s); $T_1 = 44^\circ\text{F}$ (7°C); $T_2 = 56^\circ\text{F}$ (13°C)
 $F_2 = 81$ gpm (5 L/s); $T_3 = 110^\circ\text{F}$ (43°C); $T_4 = 130^\circ\text{F}$ (54°C)
 $W_1 = 61.5$ kW
 (Data was taken from an actual 50-ton [175 kW] chiller.)

$$\text{COP} = \frac{500[100(56-44) + 81(130-110)]}{61.5 \times 3,412} = 6.7 \quad (2)$$

When transferring condenser heat to domestic water systems, the leaving temperature from the chiller condenser can be much lower, resulting in a lower energy consumption and much higher COP:

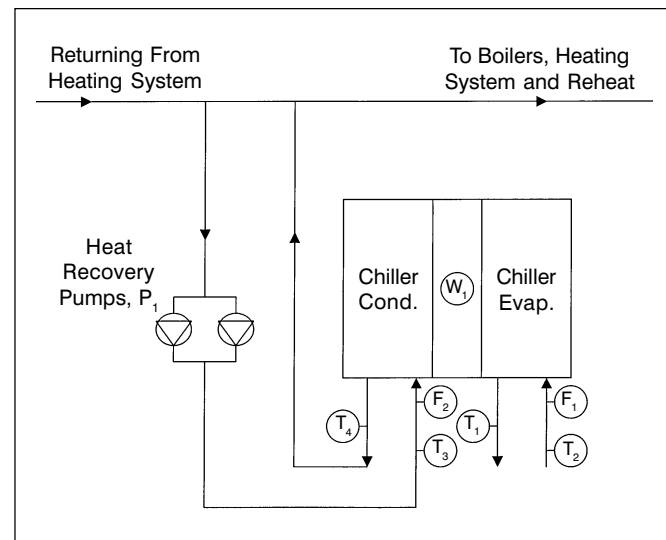

Figure 3: Space hot water heating.

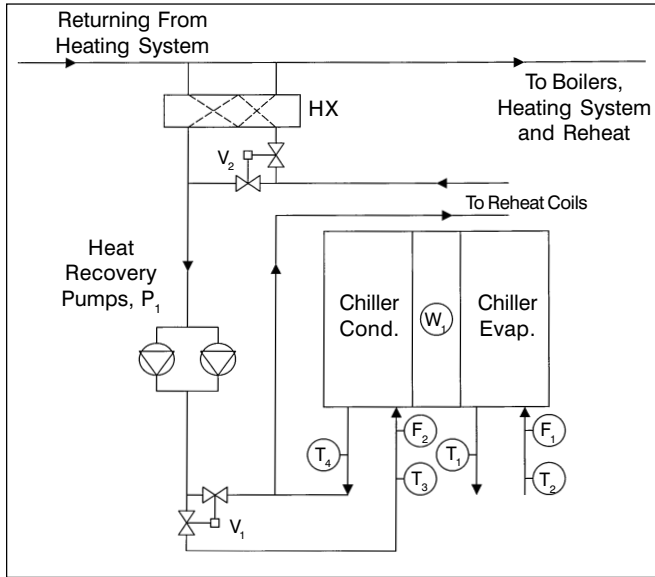

Figure 4: Reheat coils.

$$\text{COP} = \frac{500[100(56-44) + 71.5(90-70)]}{33.5 \times 3,412} = 11.5 \quad (3)$$

It is evident from these values of COP that very significant energy savings can be made, particularly when the central chillers are air cooled with typical COPs of less than 3.0.

From Equation 2:

$$\text{Heat Recovered/Hr} = 500 \times 81 \times 20 = 810 \text{ MBH} \quad (4)$$

Similarly, from Equation 3:

$$\text{Heat Recovered/Hr} = 500 \times 71.5 \times 20 = 715 \text{ MBH}$$

Recognizing these equations, the following are piping diagrams for methods of heat recovery. A number of piping accessories such as shut-off valves are not shown for clarity.

Domestic Water Heating

Figure 2 describes the piping and equipment arrangement for transferring heat to the domestic water including the heat recovery pumps (P_1). This requires a circulating loop due to the variable flow in the domestic water system. This loop consists of a double-wall heat exchanger, circulating pumps (P_2), blending tank, and interconnecting piping. The water is circulated through the heat exchanger to the tank and back to the heat exchanger. Maximum recovery of heat is achieved by having an active heat exchanger.

Supply water to domestic water systems can vary from 45°F to 60°F (7°C to 16°C). Most makeup water flows to the pump from the bottom of the tank. Typical condenser leaving water temperatures are 90°F to 100°F (32°C to 38°C). This can be varied to suit the installation and to achieve maximum chiller performance.

Hot Water Heating

Hot water for space heating has been traditionally at tem-

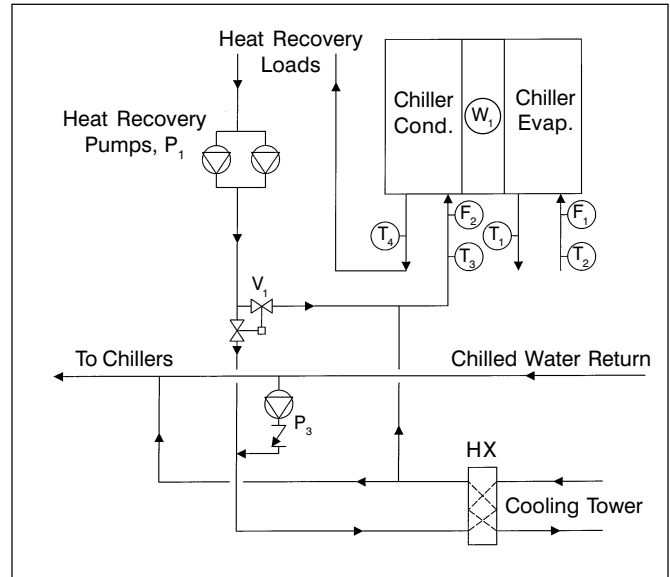

Figure 5: Cooling tower connections.

peratures such as 180°F (82°C) supply and 160°F (71°C) return. With the diminishing amount of direct radiation such as finned tube and the increased use of radiant heaters and fan/coil types of terminal units, there is no need for such high temperatures. Along with this comes the development of the condensing boiler that can operate with temperatures down to 80°F (27°C). The old standard of 80% boiler efficiency has changed to efficiencies higher than 90%. If these lower operating temperatures are available, the heat recovery chiller can be used for space heating. The circuit is shown in Figure 3. The heat recovery chiller is located on the return water-side of the boiler.

Supply Water For Reheat

Although reheat coils are normally supplied by the hot water heating system, opportunities may exist for providing heating from a heat recovery chiller. This eliminates the need to run boilers in the summertime. Because there is no reason to heat 55°F (13°C) air with 180°F (82°C) water, a heat recovery chiller can be useful in providing warm water to the reheat coils at 110°F (43°C) in the summer and 130°F (54°C) in the winter. Figure 4 describes the reheat chiller as the prime source of heat for the reheat coil with a heat exchanger for heat from higher temperature boilers when no heat is available from the reheat chillers. Obviously, if the boilers are operating at lower temperatures, the heat exchanger is not needed.

One possible application is to use recovered heat from these chillers in natatoriums where reheat is required for satisfactory operation.

Excess Heat

If the heat recovery chiller generates excess heat when it is delivering the required cooling capacity, a heat exchanger must be provided to deliver this heat to the cooling tower. A careful evaluation of the available heat from the condenser

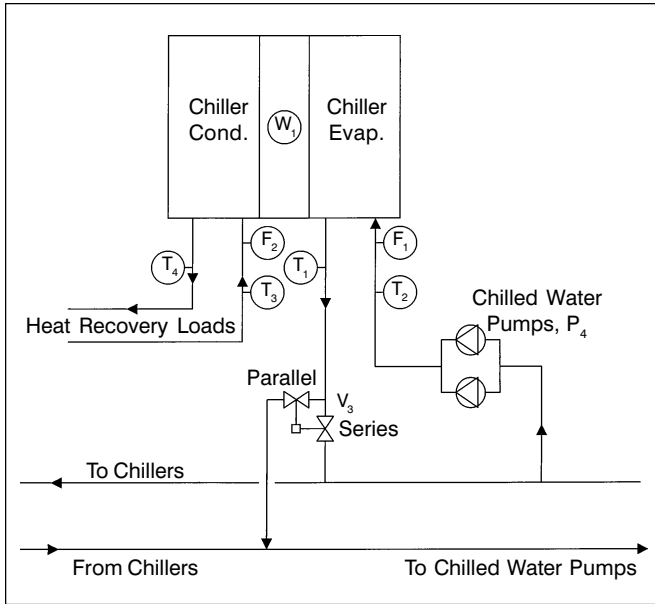

Figure 6: Chiller cooling load.

may prove that this heat exchanger is not needed. Figure 5 describes this heat exchanger and the necessary piping. When the heat recovery chiller is not required, the same heat exchanger can be used for free cooling. Pump 3 then circulates the return water through the heat exchanger.

Cooling Load From Heat Recovery Chiller

Obviously, one of the important factors in the design of the heat recovery chiller is the usefulness of the cooling effect of the chiller. Figure 6 describes the connection of the cooling load of the heat recovery chiller. (Of course, this is the most important load, as there must be a cooling load for the heat recovery chiller to be a viable answer to heat recovery.)

As shown in Figure 6, the chiller can be connected in series or parallel to the main chillers. This is a decision that must be made by the designer on each application.

The heat recovery circulating pumps (P_4) are selected to meet the design chilled water flow of the chiller. They run when the chiller is in operation and are constant speed. An evaluation of the head of these pumps must be made carefully when the heat recovery chillers are piped in parallel with the main chillers.

Combination Heat Recovery Loads

Actual installations often have several loads that can be serviced by the heat recovery chiller. Therefore, the piping may be a combination of the previous piping diagrams. Along with the loads to be serviced, the piping diagram would include the chilled water piping of Figure 6.

For example, if the hot water heating system is of the lower temperature design, such as 130°F (54°C) supply water temperature, and it is desired to provide heat to the domestic water system, the control system for the heat recovery chiller can be set up to automatically select the load that provides the greatest benefit from the heat recovery chiller. Valve V_2 transfers the heat

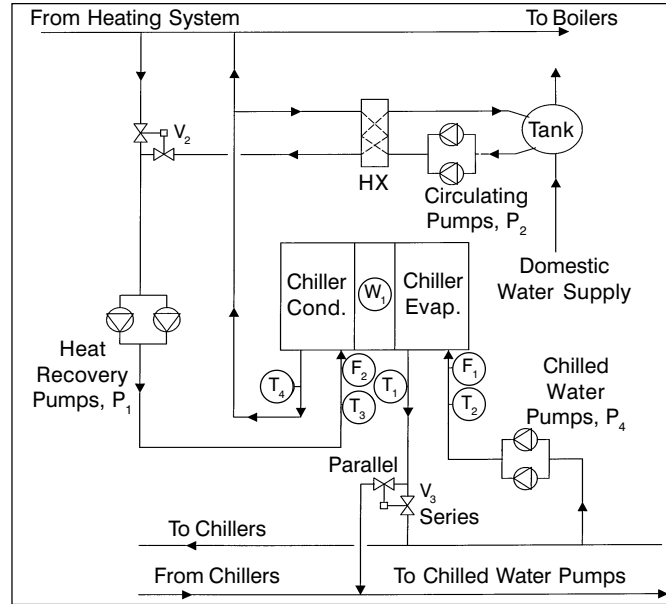

Figure 7: Combination system.

from the hot water heating system to the domestic water system when it is more efficient to use the heat for the domestic water.

The overall piping of this system is shown in Figure 7. It is a combination of Figures 2, 3, and 6. This diagram is for a system with low-temperature boilers and use of the recovered heat for space heating, and domestic water heating. The chilled water produced is used in series with the central chillers.

Control of Heat Recovery Chillers

It is obvious that the control of heat recovery chillers is different than that for ordinary chillers. The control of the condenser heat becomes the principal objective of the control system, not necessarily the production of a specific number of tons of cooling or a chilled water supply temperature.

For example, several of the above piping configurations assume that no heat is being rejected to a cooling tower or other heat absorbing equipment. How can this be done? With most applications of these chillers, the desire is to produce a specific amount of heat from the condenser, and the cooling effect is secondary. To achieve this, it is necessary to control the chiller operation by the amount of heat that is derived from the chiller. This can be done by maintaining a particular temperature for the water leaving the condenser. Other applications may require the control of the water temperature entering the condenser.

As has been stated, this system only makes sense when there is a simultaneous need for heating and cooling and must run as many hours as possible to deliver the promised paybacks. Further, when the dedicated heat recovery chiller is operating to satisfy the facility's hot water requirements, there must be a chilled water requirement in the building that meets or exceeds the hot water demand. If this is not the case, the heat recovery system will subcool the chilled water loop and eventually lock out on a low-temperature fault (freeze-stat). Similarly, if the dedicated heat recovery chiller is operating to satisfy

the facility's chilled water requirement, a hot water requirement in the building must meet or exceed the chilled water demand. If this is not the case, the heat recovery system will overheat the hot water system and eventually lock out on high temperature fault (high head pressure).

It has been discovered that the best way to operate the dedicated heat recovery chiller is to always set the control point (hot water or chilled water) to the side of the system that has the lowest demand. In doing this, we are always ensured of operating the heat recovery system during the maximum available hours for maximum economic impact on the facility.

This can be done by simply monitoring the temperatures on the side of the system (hot water or chilled water) that is not being controlled actively by the dedicated heat recovery chiller. That is, if the chiller is controlling to a leaving hot water temperature, thus producing chilled water as a by-product, then the control system must monitor the entering chilled water temperature. If this temperature drops below a predetermined setpoint, indicating a lack of chilled water load, the control point of the dedicated heat recovery chiller is changed over to the chilled water-side of the system. This ensures that the heat recovery system only produces the amount of heat that can safely be absorbed from the facility's chilled water system. This logic

can be applied similarly when in the chilled water control mode. This control may be easily accomplished by the building control system or can come prepackaged within the dedicated heat recovery chiller's control system. Such chillers are being produced with automatic switchover from control of the amount of cooling to the amount of heat recovered.

Installations of these chillers have proved the need to train chiller plant operators to understand the need to operate the heat recovery chillers as many hours as possible. Likewise, the owners and managers of these chillers must understand the operation of these chillers to ensure that they operate as many hours per year as possible.

The application of heat recovery chillers requires detailed evaluation of each installation. Success will be determined by the care provided for this evaluation. The use of heat recovery chillers is an old procedure for energy conservation, but the development of digital control, along with special types of chillers and condensing boilers, is opening a new field of efficient chilled/hot water operations with the resultant energy conservation.

Acknowledgments

Figures supplied by Thomas H. Durkin, P.E., and Benny L. Kincaid. ●

Advertisement in the print edition formerly in this space.