

# Geothermal Central System

By **Thomas H. Durkin, P.E.**, Member ASHRAE; and **Keith E. Cecil, P.E.**, Member ASHRAE

**T**he next generation of geothermal systems for school buildings is a recent synthesis of three technologies that separately have proven to be effective: geothermal (earth-coupled) heating and cooling; dedicated heat recovery chillers; and the modern two-pipe HVAC system.

From two-pipe HVAC, comes economy and simplicity for school designs, and the proven ability to heat large buildings with low-temperature water (see sidebar on *Modern Two-Pipe System*). From dedicated heat recovery chillers comes a proven machine that can be programmed to simultaneously produce 44°F (7°C) cooling water and 130°F (54°C) heating water. And, from geothermal, comes an efficient heating and cooling source. The geothermal systems discussed in this article are closed systems, circulating an engineered heat transfer solution.

#### **Another Heat Pump Article?**

Rather than multiple distributed compressorized units throughout a building (conventional geothermal heat pumps), this concept has a single unit located in a central mechanical room. The heart of the system is a heat recovery chiller/heater, or Geo-H/C. It is a single unit (multiple refrigeration circuits provide redundancy) that will heat the building in the winter, cool it in the summer, do both in the spring and fall, and preheat the domestic hot water if demand is high enough.<sup>1</sup>

Geo-H/C can be connected to either a

two-pipe or a four-pipe building system. All of the air-side equipment would be standard air handlers, unit ventilators or fan coils. This configuration can operate air-side economizers, and it can use the well water to cool the building directly when the ground temperature and indoor humidity allow, thus giving two sources of free cooling. When outside temperatures are cool, air-side economizers on AHUs and unit ventilators provide cooling without any compressors running; and when the well return temperature is cool enough, the sensible cooling mode provides air conditioning, again without compressors operating. Economizer availability in this scheme is seen as a significant efficiency benefit (see sidebar on *Economizers in Schools*).

---

#### **About the Authors**

**Thomas H. Durkin, P.E.**; and **Keith E. Cecil, P.E.**, are partners at Durkin & Villalta Partners Engineering in Indianapolis.

## Modern Two-Pipe System

Traditional (old) two-pipe designs were characterized by comfort complaints due primarily to the seasonal changeover from heating to cooling in the spring and back to heating in the fall. A modern two-pipe system can change over daily in as little as 15 minutes. Modern two-pipe systems are a good fit in spaces that have high internal heat gain, such as schools, so that air-side economizer operation can accommodate the need for concurrent heating and cooling. The E-Source pamphlet<sup>5</sup> contains detailed information about design and operation. At least 170 modern two-pipe schools are operating in the Midwest.

Figures 2 and 3 show the three water-flow arrangements for each building system. These schemes have two-position, three-way valves to reverse the water flow from heating to cooling, and two-way, two-position valves that open for water-side economizer (sensible cooling) operation. Figure 4 shows at least four months of the year when the well field temperature is below 60°F (16°C), which would be suitable for sensible cooling, if the outside air dew point is low enough to avoid elevated space relative humidity.

### Incremental Equipment Efficiencies

Table 1 shows one manufacturer's performance data for a 50 ton (176 kW) scroll compressor Geo-H/C operating at various temperatures available from the geothermal well field. In the heating mode, the unit typically operates to maintain a hot water reset schedule (condenser leaving water temperature [LWT]) from 90°F (32°C) LWT at 60°F (16°C) outside air

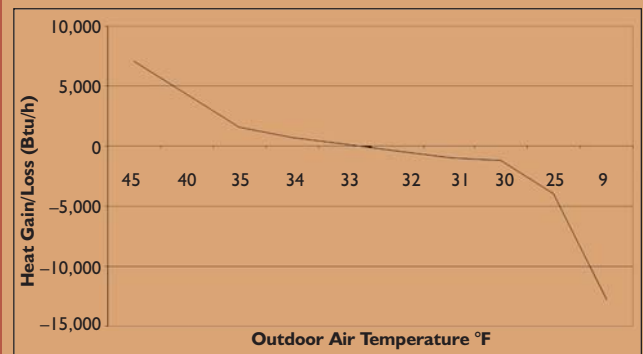

Figure 1: Typical classroom winter heat gain/loss.

## Economizers in Schools

Figure 1 shows the load in a classroom at various outside air temperatures, indicating that there is a break point at 32°F (0°C), above which the room will be heat positive. If one were to say that 55°F (13°C) were the economizer setpoint (above which mechanical cooling would run) then all the bin hours between 55 and 32 would be economizer hours lost in a decoupled makeup air scheme. Indianapolis bin data puts this number at 3,500 hours per year, although only about 800 of them occur when school is in session.

temperature (OAT) up to 130°F (54°C) LWT at 10°F (-12°C) OAT and colder. The heating COP in the chart is calculated at 120°F (49°C) LWT. In the cooling mode, the Geo-H/C operates to maintain an evaporator LWT of 44°F (7°C).

In central Indiana, initial well field temperatures are in the mid- to upper-50s (°F), which will rise about 10°F (5.6°C) over

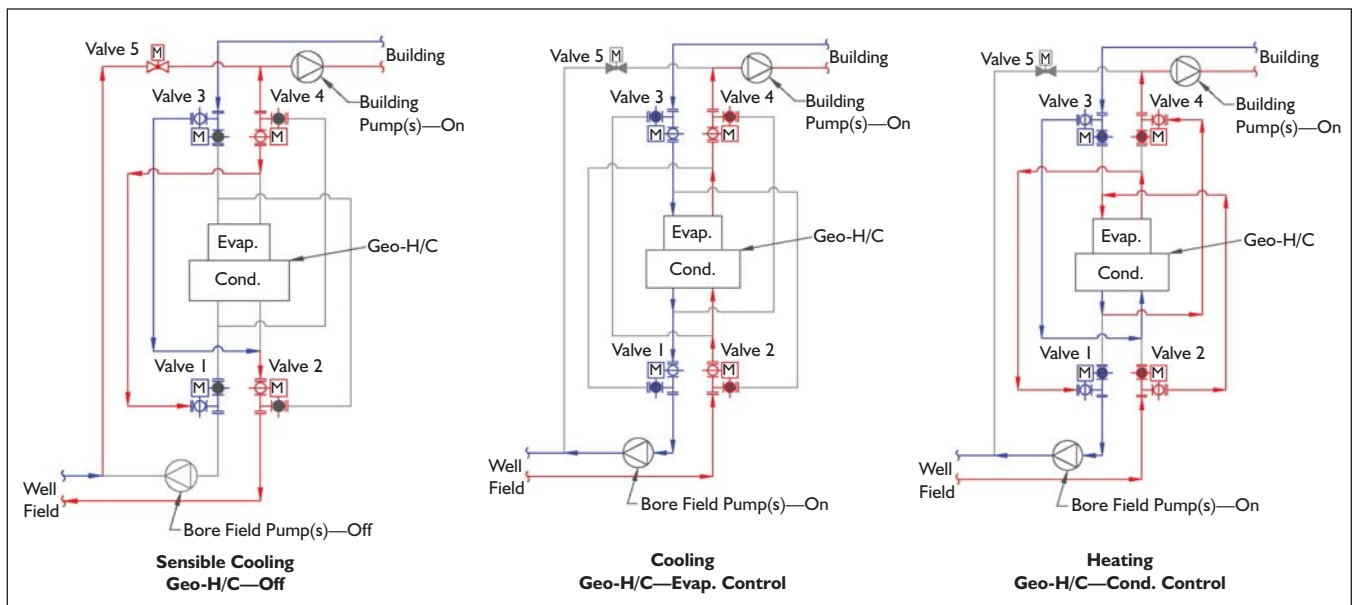

Figure 2: Two-pipe Geo-H/C piping arrangements.

the course of a cooling season. The power requirements in this chart are for the Geo-H/C only and do not include an adjustment for pump power or fan power.

The Geo-H/C COP should be translated into a total system COP for an accurate comparison of one system versus another. This example is for wintertime heating with a unit ventilator air-distribution system from a nominal 50 ton (176 kW) Geo-H/C module. Geo-H/C is at 40°F/34°F (4.4°C/1°C) evaporator temperatures. The pump motors are all premium efficiency with speed drives, so the net effect is 87%.<sup>2</sup>

- Geo-H/C: 46.8 kW in, 594.7 MBH out, heating COP = 3.72;
- Well field (evaporator) pump at 145 gpm (9 L/s) and 80 ft (24 m) total dynamic head: 3.905 hp at 87% motor/drive efficiency, 3.34 kW;
- Building (condenser) pump at 119 gpm (8 L/s) and 80 ft (24 m) total dynamic head: 3.23 hp at 87% motor/drive efficiency, 2.76 kW;
- Unit ventilator fans: 15 at 0.3 hp each, 3.35 kW;
- Total system kW = 56.25 in and 594.7 MBH out; and
- Total system COP = 3.09.

Table 2 restates the Geo-H/C heating efficiency in dollars for various average electric rates. This can be compared to boiler efficiencies and the cost of other fuel sources. A past ASHRAE Journal article<sup>3</sup> places the effective cost per therm of heat at \$1.80 from a conventional boiler and \$1.32 from a condensing boiler, low-temperature heat system. This is based on a burner-tip price of \$1.20 per therm of natural gas. Other fuel sources, such as propane and fuel oil, will be significantly higher. These numbers do not include pump or fan power required for distribution of heat.

### Payback Calculation

“Commercial Heating and Cooling Loads Component Analysis”<sup>4</sup> lists average consumption of gas and electric for several building types, by use. Looking at this data for new schools, it shows an average use of gas and electric according to Table 3.

At \$1.20 per therm for gas and \$0.10/kWh (0.36 MJ) for electric, a 100,000 ft<sup>2</sup> (9290 m<sup>2</sup>) school building in Washington, D.C., costs \$138,000 per year to operate, or \$1.38/ft<sup>2</sup>/year; heating is \$45,720/year from a total gas bill of \$53,400; and cooling is \$14,890/year from a total electric bill of \$84,600.

In most climate zones, the primary justification for a geothermal system must be based on improvements in heating efficiencies. A geo-cooling arrangement will be operating at around a COP of 6.0 to 6.5 versus a COP of about 4.1 (IPLV = 14.0 EER) for an air-cooled chiller. This represents an efficiency gain of about 50%, a significant improvement, but only 3.5% decrease in total building energy (see Washington, D.C., data in

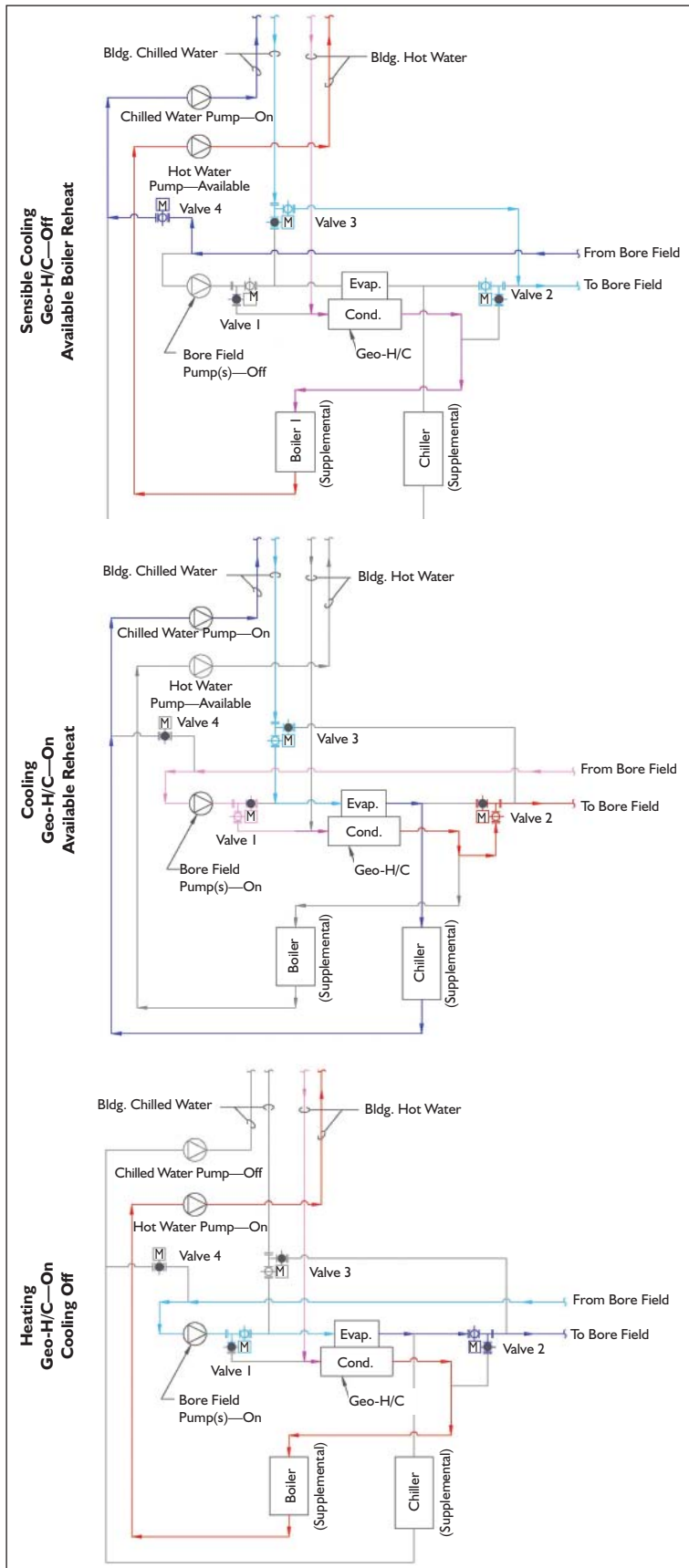

Figure 3: Four-pipe partial Geo-H/C arrangements.

*Advertisement formerly in this space.*

*Advertisement formerly in this space.*

Table 3). In terms of the dollar savings, at \$0.10/kWh (0.36 MJ), it only amounts to \$7,445 per year for a 100,000 ft<sup>2</sup> (9290 m<sup>2</sup>) building.

However, heating is a much larger piece of the total energy use and cost, and the potential improvement by going to a geothermal system would be dramatic. Per Table 2, at a 60°F (16°C) well temperature and \$0.10/kWh (0.36 MJ), the efficiency improvement versus a conventional boiler system would be 65%, saving about \$29,718 per year in the Washington, D.C., school example. Improvement versus a condensing boiler/low-temperature heat arrangement would be less, about 53% savings, worth \$24,232 per year.

This adds up to a savings of between \$31,700 and \$37,200 per year depending on the baseline system to which geothermal is being compared. The potential savings is balanced against the first cost premium for the geothermal design. The well field is going to be a big expense. Rule-of-thumb cost for boreholes (wells) in central Indiana is \$5,000 per 400 ft (122 m) well (summer, 2006), with a capacity of 2 tons (7 kW) cooling and 20 MBH heating. (See sidebar *Well Field Design*. The capacity and cost can be highly variable.) It costs approximately \$500,000 to install a geothermal system for a 100,000 ft<sup>2</sup> (9290 m<sup>2</sup>) school to save \$32,000 to \$38,000 per year. This equals a payback of 15.6 to 13.1 years. It does not consider any differential equipment cost. Once those are considered (i.e., not installing chillers and boilers, smaller mechanical room, etc.), the payback may become more manageable, but again, that depends on the system to which the geothermal is being compared.

Obviously, the biggest variable in payback analyses is going to be the cost of natural gas in the future. During the winter of 2006–07, gas was generally available for around \$1 per therm, versus the \$1.20 used in the earlier calculations, and versus the \$1.40 per therm seen many places in 2005. The Energy Information Administration ([www.eia.doe.gov](http://www.eia.doe.gov)) is predicting comparatively stable energy prices through 2030, with inflation affecting all energy sources (gas, petroleum products, and electricity) equally.

### Lexington Elementary School

Lexington Elementary School, Scott County, Ind. (45,000 ft<sup>2</sup> [4181 m<sup>2</sup>], 300 students) was built in 1925 and renovated with air conditioning in 1985. Natural gas is not available in that part of the state, so in 1985, the system selected for Lex-

Well Temp.	Heating COP	Cooling COP	Cooling kW/ton
80°F	5.9	5.4	0.65
70°F	5.3	6.1	0.58
60°F	4.7	6.8*	0.52*
50°F	4.1	Free Cooling	0.00
40°F	3.7	Free Cooling	0.00

\*Minimum condensing temperatures require head pressure control when well water temperatures are below 65°F in the cooling mode. This will limit efficiency improvements below that temperature.

Table 1: Geo-H/C operating efficiency.

	Total Gas	Gas Used For Heating	Total Elect.	Elect. Used For Cooling	Heating (% of Total Energy)	Cooling (% of Total Energy)
<b>Minneapolis</b>	84.1	77.4	29.9	3.0	68%	2.6%
<b>Chicago</b>	62.4	55.8	28.5	3.5	61%	3.8%
<b>Washington</b>	44.5	38.1	28.9	5.1	52%	7%
<b>Los Angeles</b>	23.4	17.2	28.6	6.0	33%	11.5%
<b>Houston</b>	22.7	16.3	32.3	9.6	29.6%	17.5%

Table 3: Energy consumption for schools, kBtu/ft<sup>2</sup>/yr.

Electricity per kWh	Well Temperature			
	70°F	60°F	50°F	40°F
\$0.07	\$0.38	\$0.43	\$0.50	\$0.57
\$0.08	\$0.44	\$0.50	\$0.57	\$0.65
\$0.09	\$0.49	\$0.56	\$0.64	\$0.73
\$0.10	\$0.55	\$0.62	\$0.71	\$0.81
\$0.12	\$0.66	\$0.75	\$0.86	\$0.98
\$0.15	\$0.83	\$0.93	\$1.07	\$1.22

(Does not include pump or fan power.)

Table 2: Cost per therm of Geo-H/C heat.

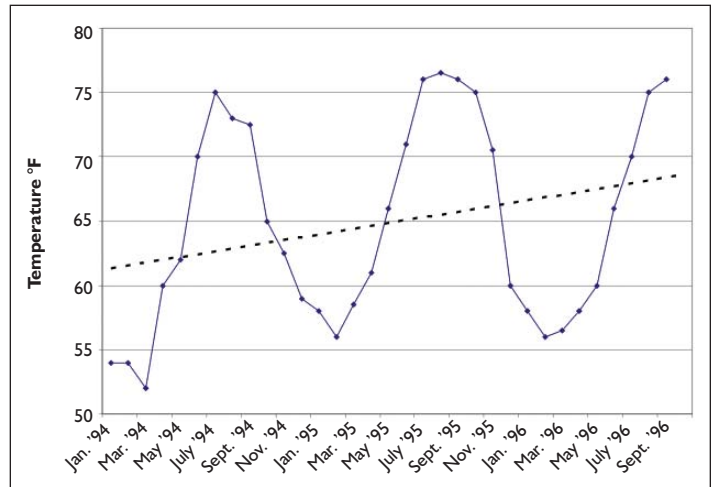

Figure 4: Borehole field return temperatures.

ington was the self-contained, air-source heat pump—one per classroom. By 2005, the heat pumps were dying, O&M costs were increasing, and poor indoor air quality was a concern. The options considered for system upgrade were:

1. Direct replacement of the air-to-air heat pumps with the addition of a decoupled makeup air system to address the IAQ concerns.
2. Geothermal heat pumps with decoupled makeup air system.
3. A modern two-pipe unit ventilator system designed per the E-Source pamphlet,<sup>5</sup> with an air-cooled chiller and the following boiler options: (a) propane and (b) fuel oil.
4. An air-cooled chiller system with electric resistance heat.
5. A geothermal system with a central heater/chiller (Geo-H/C) and two-pipe unit ventilators serving the classrooms.

The owner had operating experience with the modern two-pipe design, and it was their preference from a cost and comfort standpoint. The owner preferred not to consider fuel oil. The heat pump options were not considered further, due to the cost and difficulty of retrofitting makeup air ductwork into the existing building.

The engineers agreed to proceed with full design of Options 3a, 4, and 5, and bid pricing was received as follows: Option 4 (electric) = \$866,500, (\$19.26/ft<sup>2</sup>); Option 3a (propane two-pipe) = \$966,300 (\$21.47/ft<sup>2</sup>); and Option 5 (Geo-H/C) = \$1,102,500 (\$24.50/ft<sup>2</sup>). The Geo-H/C price included 45 boreholes (wells) 300 ft (91.4 m) deep.

If natural gas had been available at this site, the installed cost of the two-pipe system would have been \$880,300 (\$19.56/ft<sup>2</sup>), which is the propane cost less the propane tank and enclosure.

Annual heating and cooling costs were modeled as follows: electric = \$25,710; propane = \$16,211; and Geo-H/C = \$7,922. (If natural gas had been an option, its annual heating/cooling cost would have been \$12,833.) Payback versus the electric heat option would be: propane = 10.5 years; Geo-H/C = 13.2 years; and natural gas (if available) = 1 year. Payback of Geo-H/C versus natural gas two-pipe would be 45 years.

Currently, five buildings are operating with the Geo-H/C system. Initial operating data is very favorable.

### Well Field Thermal Imbalance

The issue of well field thermal imbalance is an occasional concern. In buildings that run during the summer, the total number of Btus put into the ground will usually exceed the total number removed from the ground in winter. Over time the ground temperature will rise. It may become severe enough to limit the cooling capacity of the system. Because the main justification for geothermal is on the heating side, some may say that rising ground temperatures actually help the heating efficiency, which is true as long as it doesn't inhibit the ability to cool. *Figure 4* shows measured borehole fluid return temperature of a heat pump system, showing a 1°F to 1.5°F (0.6°C to 0.8°C) per year rise.<sup>6</sup>

It is believed that the Geo-H/C concept, with its ability to run two kinds of economizer cooling, creates less long-term thermal imbalance than a conventional decentralized heat pump system. Theoretically, Geo-H/C allows for a smaller bore-field since field size often is dictated by the total cooling Btus rejected to the earth.

### Improving the Payback: Partial Geothermal

A partial (or hybrid) geothermal system is an attempt to balance the high cost of bore-field construction with the efficiency gains. According to computer simulations, out of 8,760 hours in a year, a school operates only 90 hours of the time above 65% of the peak cooling load, only 30 hours a year above 65% of the peak heating load, and less than 140 hours a year at more than 50% of peak heating load. It would seem that a hybrid system, using the highly efficient geo-source for most of the

## Well Field Design

Many factors affect the design and cost of a well field for a geothermal system. They may include the presence (or lack) of an aquifer, rock strata, soil type, local climate/rainfall, undisturbed earth temperature, proximity to other geofields, field geometry, etc. As early in the design process as possible, it is always a good idea to drill at least one test well and perform a thermal conductivity test so that a better sense of thermal performance and cost of the field will be known. The drill logs should be included in the final design documents. The terms "well" and "borehole" are used interchangeably in this article, although the authors are aware that in areas other than Indiana, a "well" would imply removing water from the ground rather than circulating fluid through a closed pipe in the well casing, which is the case discussed here.

hours, and using conventional equipment to supplement during the remaining hours has merit. A specific concern is that a protracted cold spell when the bore-field return temperature is low and the geothermal heating capacity is at its lowest, the building heating demand may be the greatest.

### Conclusion

Geothermal, however it is used, is considerably more efficient than conventional heating or cooling options. Because of the bore-field cost, it comes with a fairly steep price tag, and paybacks can be lengthy depending on the baseline system to which the geothermal is compared. The partial geothermal concept offers improved payback with minimal loss of operating efficiency.

Of the possible ways of using this impressive efficiency, it is felt that earth coupling a conventional central system (the Geo-H/C concept) has significant merit. With two types of economizers available, the Geo-H/C concept provides excellent efficiency.

### References

1. Rishel, J.B., T.H. Durkin. 2003. "Dedicated heat recovery." *ASHRAE Journal* 45(10):18–23.
2. Rishel, J.B., T.H. Durkin, B. Kincaid. 2006. *HVAC Pump Handbook*, 2nd ed., Table 10.3. N.Y.: McGraw-Hill Publishing.
3. Durkin, T.H. 2006. "Boiler system efficiency" *ASHRAE Journal* 48(7):51–57.
4. Huang, J., E. Franconi. 1999. "Commercial Heating and Cooling Loads Component Analysis" University of California—Berkeley, LBL-37208.
5. Kinney, L. 2001. "Two-Pipe HVAC: It May Be Twice As Good As Four." Platts E-Source ER-01-13.
6. Stiles, L. and A. Howard. 2005. "GeoExchange Technology II." Presentation Hosted by New Jersey Central Power and Light.

### Bibliography

Henderson, H.I. 1999. "Limitations of Measured Commercial Building Loads on Geothermal System Sizing." Presentation at 1999 ASHRAE Annual Meeting. ●