

## Multistack Chiller Design Increases Production of Carbonated Beverages by 43%!

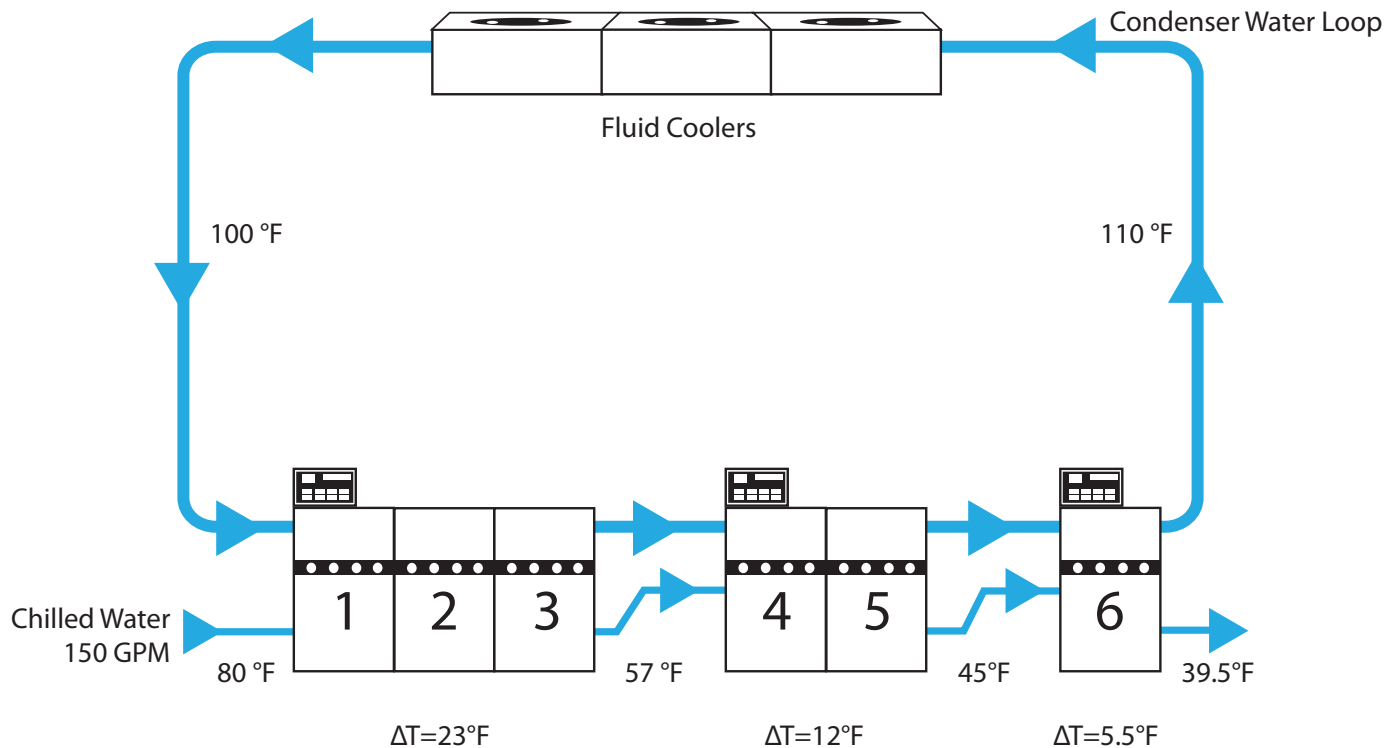

Multistack has a 20-year history of being the right modular chiller for any standard or custom application. All too often though, what a customer thinks is custom, is actually standard operating fare for the Multistack product catalog.

An example of this took place in Arizona where a carbonated beverage manufacturer's needs showcased what a standard Multistack chiller could do. The carbonation stage of soft drink production requires high-pressure injection of carbon-dioxide gas into the drink mixture to reach the desired level of carbonation before bottling takes place. Lowering the temperature of the mixture below 40° F increases the absorption rate of carbon-dioxide gas—and it does it at a much lower pressure rate! This resulted in an astounding 43% increase in the production rate of one-liter bottles for the company utilizing Multistack chillers.

In a situation where supply water temperatures fluctuate, Multistack can install a surge tank into the chilled water circuit assuring controlled water temperature throughout the cooling process. Since the chilled water is used in the final product, the Multistack cascading chillers in this application were engineered with stainless steel piping that meets FDA requirements.

Similar results are possible in almost every carbonated beverage bottling plant, without going to the expense of a completely custom designed package. Multistack's 20-year history of providing elegant solutions to chiller requirements is the basis for the company motto: Originators. Innovators. Never the Imitators.